

Horizontal Reaction, P2 = 155 lbs  
Horizontal Reaction increased to 395 lbs  
w/ (1) #10 sds installed into return lip

MAXIMUM REACTION (LBS)			
	Web/ Block	X-U	UPLIFT P1
1224HD14D	035	2	1450
	046	2	1450
	057	2	1450
1226HD14D	035	3	1940
	046	3	2325
	057	3	2325

Values based on steel thickness of 1/4" - 1/2"

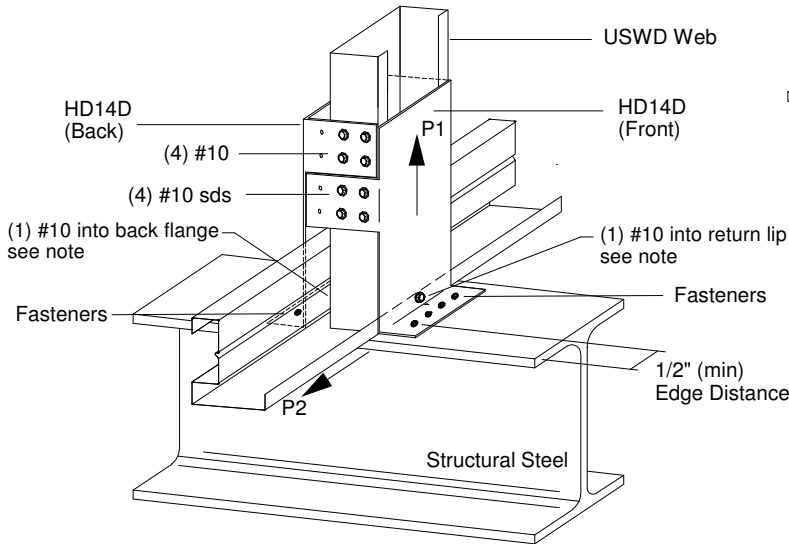
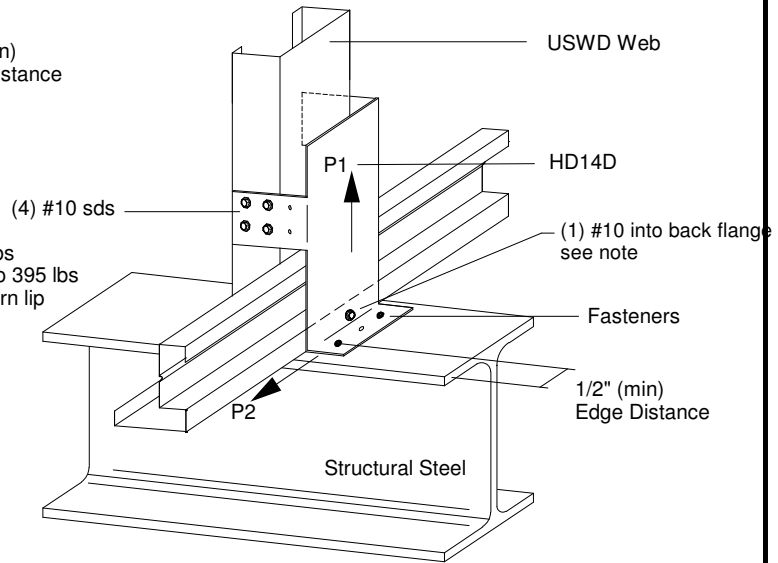

Horizontal Reaction, P2 = 310 lbs  
Horizontal Reaction increased to 795 lbs  
w/ (1) #10 sds installed into return lip and  
back flange

MAXIMUM REACTION (LBS)			
	Web/ Block	X-U	UPLIFT P1
(2) 1224HD14D	035	2	3100
		3	3860
(2) 1226HD14D	035	2	3100
		3	4650
	046	4	6200
		5	6400
	057	5	6400

Values based on steel thickness of 1/4" - 1/2"

- 1) Min. screw spacing & edge distance = 9/16".
- 2) Min. PAF spacing = 1", Min. Edge Dist = 1/2"
- 3) Min. bearing width = 3".
- 4) Refer to the Hilti Product Technical Guide for installation requirements and application limits.
- 5) Equivalent PAF's may be substituted.
- 6) Place PAF's thru or in line w/ holes in HD14D.
- 7) HD product specified is manufactured by Aegis Metal Framing. Any substitution is prohibited.
- 8) When this connection detail is applied to both plies of a 2-ply truss, the capacities double.
- 9) This detail does not indicate or imply that the depicted bearing is structurally adequate for the loads shown. Design of bearing is req'd.
- 10) Max. Reactions shown are non-concurrent.

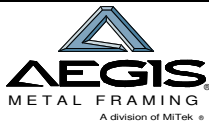

www.AegisMetalFraming.com

14515 N. Outer 40 Drive - Suite 110  
Chesterfield, MO 63017

Phone: (866) 902-3447 Fax: (314) 434-5234

## USD TRUSS TO BEARING CONNECTION 1224/1226HD14D - STRUCTURAL STEEL

DETAIL NO.

# D-SS-2

CATEGORY

STANDARD DETAILS

DATE

3/2012