

MAXIMUM REACTION (LBS)				
	Web / Block	#10 SDS	UPLIFT P1	HORIZ P2
423HD16	035	2	485	485
		3	650	485
	046	2	650	795
423HD14	035	2	485	485
		3	730	485
		4	970	485
		5	1060	485
	046	2	840	795
		3	1060	795
	057	2	940	940
		3	1060	1105
	423HD12	035	5	1215
046		4	1400	795
057		3	1400	1105
426HD14	046	4	1675	795
		5	1995	795
	057	4	1880	1105
		5	1995	1105
426HD12	035	10 ¹	2430	970
		5	2095	795
	046	6 ¹	2515	1590
		8 ¹	2955	1590
	057	5	2350	1105
		7 ¹	2955	2210

(2) Hilti X-U

(4) Hilti X-U

Values based on steel thickness of 1/4" - 1/2"

¹ Double web required

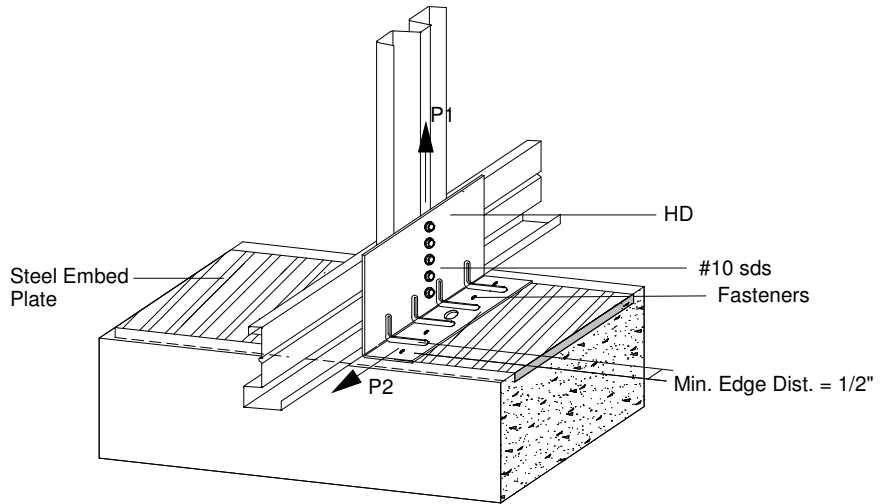
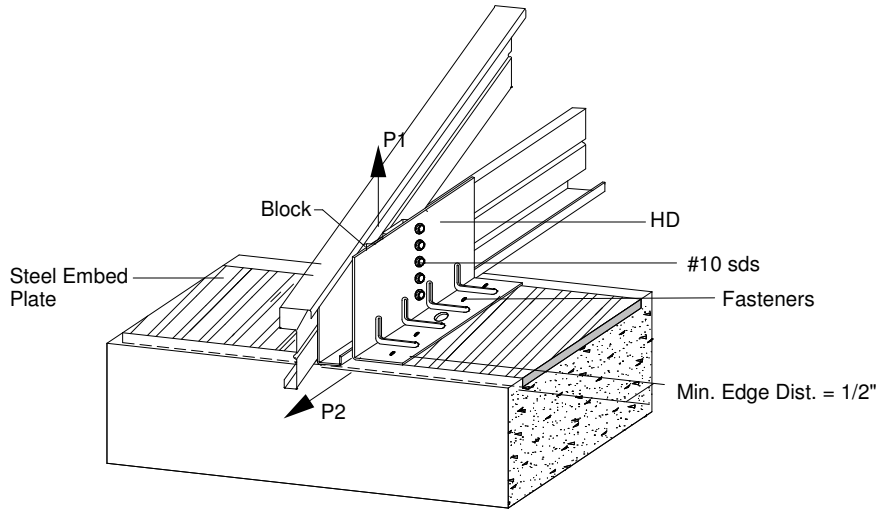

- 1) Min. screw spacing & edge distance = 9/16".
- 2) Min. PAF spacing = 1", Min. Edge Dist = 1/2"
- 3) Refer to the Hilti Product Technical Guide for installation requirements and application limits.
- 4) Equivalent PAF's may be substituted.
- 5) Place PAF's thru or in line w/ holes in HD14.
- 6) HD product specified is manufactured by Aegis Metal Framing. Any substitution is prohibited.
- 7) When this connection detail is applied to both plies of a 2-ply truss, the capacities double.
- 8) This detail does not indicate or imply that the depicted bearing is structurally adequate for the loads shown. Design of bearing is req'd.
- 9) Max. Reactions shown are non-concurrent.

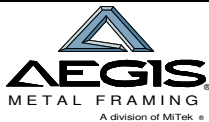

www.AegisMetalFraming.com

14515 N. Outer 40 Drive - Suite 110
Chesterfield, MO 63017

Phone: (866) 902-3447 Fax: (314) 434-5234

USC TRUSS TO BEARING CONNECTION 423HD / 426HD EMBED PLATE

Revised 5/6/11 - New 423HD14, 423HD16 and 426HD14

DETAIL NO.

C-EMB-1.1

CATEGORY

STANDARD DETAILS

DATE

5/2012